

AMS 6915

Board mount pressure sensor with digital output (I²C)

FEATURES

- Calibrated and temperature compensated pressure sensor with digital output (I²C)
- Differential, relative (gage), bidirectional differential, absolute and barometric versions
- Digital output for pressure and temperature via I²C interface
- High accuracy at RT
- Small overall error within a temperature range of 0 .. 60 °C
- Supply voltage: 3.3 V and 5 V models available
- High long term stability
- Programmable 7 bit I²C-address
- Compact DIL package
- Horizontal and vertical pressure port configurations available
- Ready to use
- RoHS and REACH compliant
- Substitute product for Honeywell's HSC series

TYPICAL APPLICATIONS

- Static and dynamic pressure measurement
- Industrial process control
- Medical instrumentation
- Heating, Ventilation and Air Conditioning (HVAC)
- Barometric pressure measurement
- Vacuum monitoring
- Gas flow measurement

GENERAL DESCRIPTION

AMS 6915 is a series of high-precision OEM pressure sensors with a digital I²C-interface in a compact DIL package for assembly on printed circuit boards (PCBs). The series is especially suitable for low and medium differential pressure measurements in applications, which require a consequent miniaturization.

The sensors in the AMS 6915 series combine a micromachined, high quality piezoresistive measuring cell with a modern, mixed-signal conditioning ASIC on a ceramic substrate. The sensors are calibrated and temperature compensated and have an operating temperature range of -25 .. 85 °C. With their digital I²C output and a supply voltage of 3.3 V or 5 V they are ideal for microcontroller applications.

The AMS 6915 series is available for various applications and pressure ranges: differential devices in pressure ranges from 0 .. 5 mbar up to 0 .. 1 bar, relative sensors for 0 .. 25 mbar up to 0 .. 1 bar, an absolute pressure variant for 0 .. 1 bar and a barometric type. Bidirectional differential devices are available in pressure ranges from -2.5 .. +2.5 mbar up to -1 .. +1 bar. Custom specific pressure ranges or further modifications are available on request.

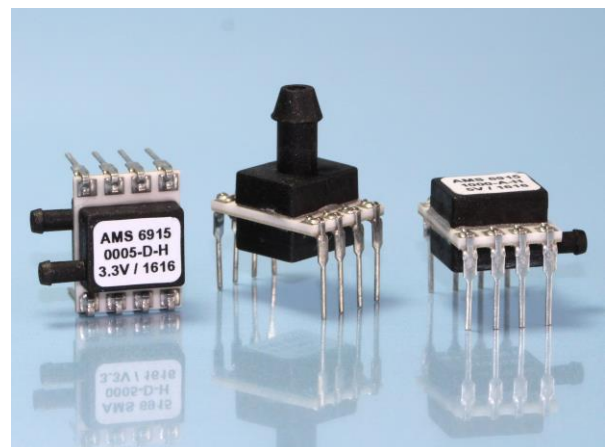

analog microelectronics

Analog Microelectronics GmbH
An der Fahrt 13, D – 55124 Mainz

Phone: +49 (0)6131/91 0730-0
Fax: +49 (0)6131/91 073-30
Internet: www.analog-micro.com
E-Mail: info@analogmicro.de

December 2018 – Rev. 1.3

AMS 6915

Amplified pressure sensor with digital output (I²C)

PRESSURE RANGES AND TYPES

| Pressure sensor code | Pressure type | Pressure range in mbar | Burst pressure ¹⁾ in bar | Pressure range in PSI | Burst pressure in PSI |
|---------------------------|----------------------------|------------------------|-------------------------------------|-----------------------|-----------------------|
| Ultra low pressure | | | | | |
| AMS 6915-0002-D-B-... | bidirectional differential | -2.5 .. +2.5 | > 0.35 | -0.0363 .. +0.0363 | > 5 |
| AMS 6915-0005-D-... | differential | 0 .. 5 | > 0.35 | 0 .. 0.0725 | > 5 |
| AMS 6915-0005-D-B-... | bidirectional differential | -5 .. +5 | > 0.35 | -0.0725 .. +0.0725 | > 5 |
| AMS 6915-0010-D-... | differential | 0 .. 10 | > 0.35 | 0 .. 0.145 | > 5 |
| AMS 6915-0010-D-B-... | bidirectional differential | -10 .. +10 | > 0.35 | -0.145 .. +0.145 | > 5 |
| Low pressure | | | | | |
| AMS 6915-0025-D/G-... | differential / relative | 0 .. 25 | > 0.5 | 0 .. 0.363 | > 7.5 |
| AMS 6915-0025-D-B-... | bidirectional differential | -25 .. +25 | > 0.5 | -0.363 .. +0.363 | > 7.5 |
| AMS 6915-0050-D/G-... | differential / relative | 0 .. 50 | > 1 | 0 .. 0.725 | > 15 |
| AMS 6915-0050-D-B-... | bidirectional differential | -50 .. +50 | > 1 | -0.725 .. +0.725 | > 15 |
| AMS 6915-0100-D/G-... | differential / relative | 0 .. 100 | > 1 | 0 .. 1.450 | > 15 |
| AMS 6915-0100-D-B-... | bidirectional differential | -100 .. +100 | > 1 | -1.450 .. +1.450 | > 15 |
| Standard pressure | | | | | |
| AMS 6915-0200-D/G-... | differential / relative | 0 .. 200 | > 5 | 0 .. 2.901 | > 72 |
| AMS 6915-0200-D-B-... | bidirectional differential | -200 .. +200 | > 5 | -2.901 .. +2.901 | > 72 |
| AMS 6915-0350-D/G-... | differential / relative | 0 .. 350 | > 5 | 0 .. 5.076 | > 72 |
| AMS 6915-0350-D-B-... | bidirectional differential | -350 .. +350 | > 5 | -5.076 .. +5.076 | > 72 |
| AMS 6915-1000-D/G-... | differential / relative | 0 .. 1000 | > 5 | 0 .. 14.50 | > 72 |
| AMS 6915-1000-D-B-... | bidirectional differential | -1000 .. +1000 | > 5 | -14.50 .. +14.50 | > 72 |
| AMS 6915-1000-A | absolute | 0 .. 1000 | > 5 | 0 .. 14.5 | > 72 |
| AMS 6915-1200-B | barometric | 700 .. 1200 | > 5 | 10.88 .. 17.4 | > 72 |

Table 1: AMS 6915 standard pressure ranges (other ranges on request)

MAXIMUM RATINGS

| Parameter | Minimum | Typical | Maximum | Units |
|---|---------|---------|---------|-------|
| Maximum supply voltage: $V_{S,max}$ | | | 6.0 | V |
| Operating temperature: T_{op} | -25 | | 85 | °C |
| Storage temperature: T_{amb} | -25 | | 85 | °C |
| Common mode pressure p_{CM} ²⁾ | | | 16 | bar |

Table 2: Maximum ratings

Notes:

- 1) Burst pressure is defined as the maximum pressure, which may be applied to one pressure port relative to the other port (or while only one pressure port is connected) without causing leaks in the sensor.
- 2) Common mode pressure is defined as the maximum pressure, which can be applied simultaneously on both pressure ports of a differential or bidirectional transmitter without causing damages, while no further differential pressure is applied.

AMS 6915

Amplified pressure sensor with digital output (I²C)

SPECIFICATIONS

All parameters apply to $T_{op} = 25\text{ °C}$ and $V_S = 3.3\text{ V}$ (3.3 V models) or $V_S = 5.0\text{ V}$ (5 V models), unless otherwise stated.

| Parameter | Minimum | Typical | Maximum | Units |
|--|--|--------------------------------|-------------------------------------|--------------------------------------|
| Digital output signal (pressure) ¹⁾ @ specified minimum pressure (see "pressure range") ²⁾ @ specified maximum pressure (see "pressure range") ²⁾ Full span output (FSO) ³⁾ Without pressure (bidirectional differential) | | 1638 14745 13107 8192 | | counts counts counts counts |
| Digital output signal (temperature) ⁴⁾ @ minimum temperature $T = -25\text{ °C}$ @ maximum temperature $T = 85\text{ °C}$ | | 256 1382 | | counts counts |
| Accuracy ⁵⁾ (pressure measurement) @ $T = 25\text{ °C}$ Ultra low pressure sensors (2.5, 5, 10 mbar) Low pressure sensors (25, 50, 100 mbar) Standard pressure sensors (> 100 mbar) | | | ± 1.5 ± 1.0 ± 0.5 | %FSO %FSO %FSO |
| Overall error ⁶⁾ (pressure meas.) @ $T = 0 \dots 60\text{ °C}$ Ultra low pressure sensors (2.5, 5, 10 mbar) Low pressure sensors (25, 50, 100 mbar) Standard pressure sensors (> 100 mbar) | | | ± 2.0 ± 1.5 ± 1.0 | %FSO %FSO %FSO |
| Error temperature measurement @ $T = -25 \dots 85\text{ °C}$ All types of AMS 6915 | | | ± 3.0 | %FSO |
| Long term stability | | | < 0.5 | %FSO/a |
| Resolution A/D converter | | 14 | | bits |
| Resolution pressure signal | | 12 | | bits |
| Resolution temperature signal | | | 11 | bits |
| Supply voltage range (V_S) for 3.3 V model | 3.0 | 3.3 | 3.6 | V |
| Supply voltage range (V_S) for 5 V model | 4.75 | 5.00 | 5.25 | V |
| Overall ratiometricity error (@ supply voltage range) | | ± 0.025 | ± 0.1 | %FSO |
| Current consumption | | | 5 | mA |
| Reaction time (10 % .. 90 % rise time) | | 0.5 | 1 | ms |
| Start up time (Power up to data ready) | | | 10 | ms |
| I²C-interface | | | | |
| Input high level | 80 | | 100 | % V_S |
| Input low level | 0 | | 20 | % V_S |
| Output low level | 0 | | 10 | % V_S |
| Load capacitance @ SDA | | | 200 | pF |
| Clock frequency SCL | | 100 | 400 | kHz |
| Pull-up resistor | 500 | | | Ω |
| Pressure changes | 10^6 | | | |
| Compensated temperature range | 0 | | 60 | °C |
| Weight | | 1.5 | | g |
| Media compatibility | See "Specification notes" ^{7) 8)} | | | |

Table 3: Specifications

AMS 6915

Amplified pressure sensor with digital output (I²C)

SPECIFICATION NOTES

- 1) The digital pressure output signal is not ratiometric to the supply voltage.
- 2) For pressure ranges see *Table 1*.
- 3) The Full Span Output (FSO) is the algebraic difference between the output signal at the specified maximum pressure and the output signal at the specified minimum pressure (see "Pressure ranges").
- 4) The digital temperature output signal is not ratiometric to the supply voltage. The digital temperature value is the sensor temperature (including self heating).
- 5) Accuracy is defined as the measurement value's maximum deviation from the ideal characteristic curve at room temperature (RT) in %FSO including the adjustment error (offset and span), nonlinearity, pressure hysteresis and repeatability. Nonlinearity is the measured deviation from the best fit straight line (BFSL) across the entire pressure range. Pressure hysteresis is the maximum deviation of the output value at any pressure within the specified range when the pressure is cycled to and from the minimum or maximum rated pressure. Repeatability is the maximum deviation of the output value at any pressure within the specified range after 10 pressure cycles.
- 6) The overall error is defined as the maximum deviation of the measurement value from the ideal characteristic curve in %FSO across the entire compensated temperature range (0 .. 60 °C).
- 7) Media compatibility of pressure port 1 (for a description of port 1, see *Figure 5*): fluids and gases non-corrosive to LCP, silicon, Pyrex, RTV silicone rubber and epoxy.
- 8) Media compatibility of pressure port 2 (for a description of port 2, see *Figure 5*): clean, dry gases, non-corrosive to LCP, silicon, RTV silicone rubber, epoxy, gold (alkaline or acidic liquids can destroy the sensor).

AMS 6915

Amplified pressure sensor with digital output (I²C)

FUNCTIONAL DESCRIPTION

The pressure sensors in the AMS 6915 series combine a high quality, piezoresistive silicon sensing element with a modern mixed-signal CMOS ASIC for signal-conditioning on a ceramic substrate. This enables high precision measurements and excellent drift and long-term stability.

The functional principle of the AMS 6915 sensors is explained using *Figure 1*.

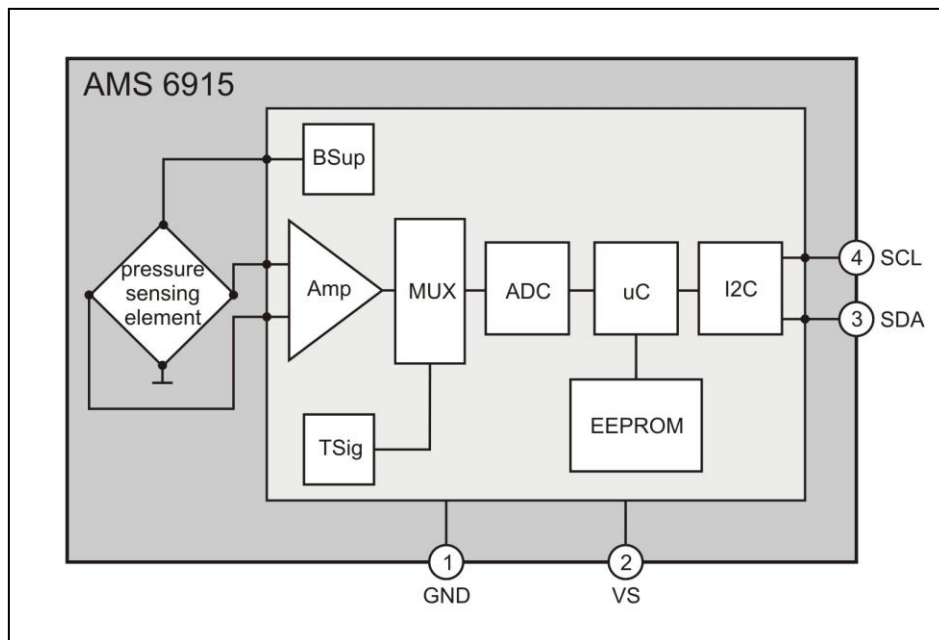

Figure 1: Functional principle

The physical pressure is measured at AMS 6915's piezoresistive pressure sensing element, where the pressure is converted into a differential voltage signal, which is almost proportional to the pressure. This differential voltage signal is corrected and conditioned by the ASIC in multiple steps.

At first the differential voltage signal from the sensing element is pre-amplified by the ASIC's amplifier stage and transmitted to the A/D converter stage (ADC) by the multiplexer stage. The ADC stage converts this voltage signal into digital values with a resolution of 14 bits. The digitized signal is corrected and calibrated in the subsequent ASIC microcontroller block.

During AMS 6915's factory calibration sensor-specific correction coefficients are determined and stored in each sensor's EEPROM. This permits sensor-specific calibration and correction (i.e. temperature compensation and linearization) of the digitized pressure signal. The temperature signal necessary for temperature compensation is generated at the ASIC's temperature reference block and is transmitted by the multiplexer stage to the ADC stage, where it is digitized. The ASIC's microcontroller block runs a cyclic program, which continuously calculates the current standardized and corrected digital pressure value using the current digitized pressure and temperature values as well as the stored correction coefficients. In addition, a standardized current digital temperature value is calculated. These calculated and corrected digital values (14 bit pressure value and 11 bit temperature value) are written to the ASIC's output registers and are continuously updated (typically every 0.5 ms).

The signal readout of the corrected digital pressure and temperature values is done via the I²C sensor interface at pin 3 (SDA) and pin 4 (SCL). The digital output values (for pressure and temperature) are not ratiometric to the supply voltage.

AMS 6915

Amplified pressure sensor with digital output (I²C)

INITIAL OPERATION

AMS 6915 is connected up electrically by mounting them on a PCB¹⁾, pins 1 to 4 have to be connected as shown in *Figure 2*.

Important: Each I²C-bus communication line has to be connected to the positive supply voltage using pull-up resistors (4.7 kΩ is recommended).

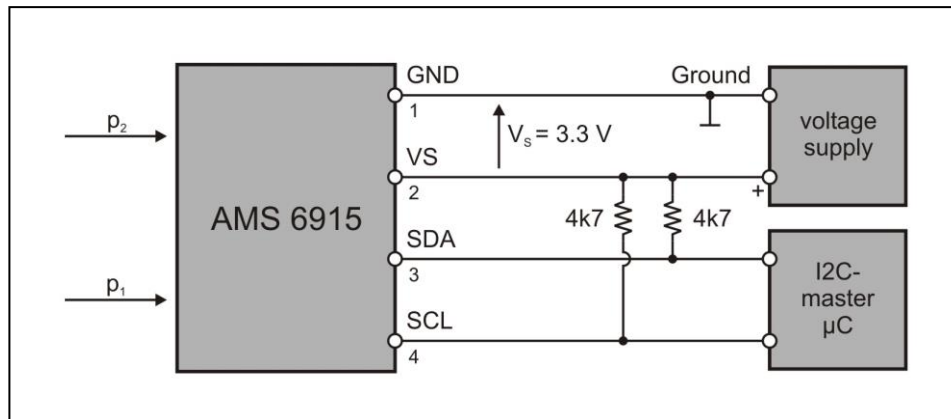

Figure 2: Principle electric circuitry

The pressure connection is established using suitable hoses²⁾ attached to AMS 6915's barbed pressure ports. Depending on the type of sensor and measuring pressure one or two of the pressure ports have to be connected up to the measuring media / volumes. For the pressures at port 1 and 2 (for port definition see *Figure 5*) the following requirements have to be fulfilled (according to the definition p_1 = pressure at port 1 and p_2 = pressure at port 2):

| | |
|--|--|
| for differential pressure types (AMS 6915-XXXX-D-...): | $p_1 > p_2$ |
| for relative / gage pressure types (AMS 6915-XXXX-G-...): | $p_1 > p_{ambient}$, p_1 = measuring pressure |
| for bidirectional differential pressure types (AMS 6915-XXXX-D-B-...): | $p_1 > p_2$ or $p_1 < p_2$ possible |
| for absolute pressure types (AMS 6915-XXXX-A-...): | p_2 = measuring pressure |
| for barometric pressure types (AMS 6915-XXXX-B-...): | p_2 = measuring pressure |

The guidelines on media compatibility have to be taken into account (see "Specification notes", 8 and 9).

Notes:

- ESD precautions are necessary, it is essential to ground machines and personnel properly during assembly and handling of the device
- For horizontal pressure port configuration Analog Microelectronics recommends a silicone hose tubing with inner diameter $\varnothing = 1.6$ mm, outer diameter $\varnothing = 3.2$ mm and for vertical pressure port configuration a silicone hose tubing with inner diameter $\varnothing = 2$ mm, outer diameter $\varnothing = 6$ mm.

AMS 6915

Amplified pressure sensor with digital output (I²C)

I²C-INTERFACE

AMS 6915 pressure sensors have an I²C-interface for digital data readout. When connected to a computer or microcontroller via a bidirectional I²C-bus, the current digital pressure and temperature measurement values can be read from AMS 6915's output register.

Communication via the I²C-bus follows a simple master-slave principle. Data transfer is always initialized by a master (e.g. a microcontroller), which sends a data request to the sensor; the AMS 6915 sensor – which always operates as slave – answers then.

The I²C-bus requires only two bus lines: a serial data line (SDA) and a serial clock line (SCL). SDA and SCL are bidirectional lines, which are connected to the positive supply voltage via pull-up resistors.

AMS 6915 communication protocol adheres to a standard I²C communication protocol (given in *Figure 3*)¹.

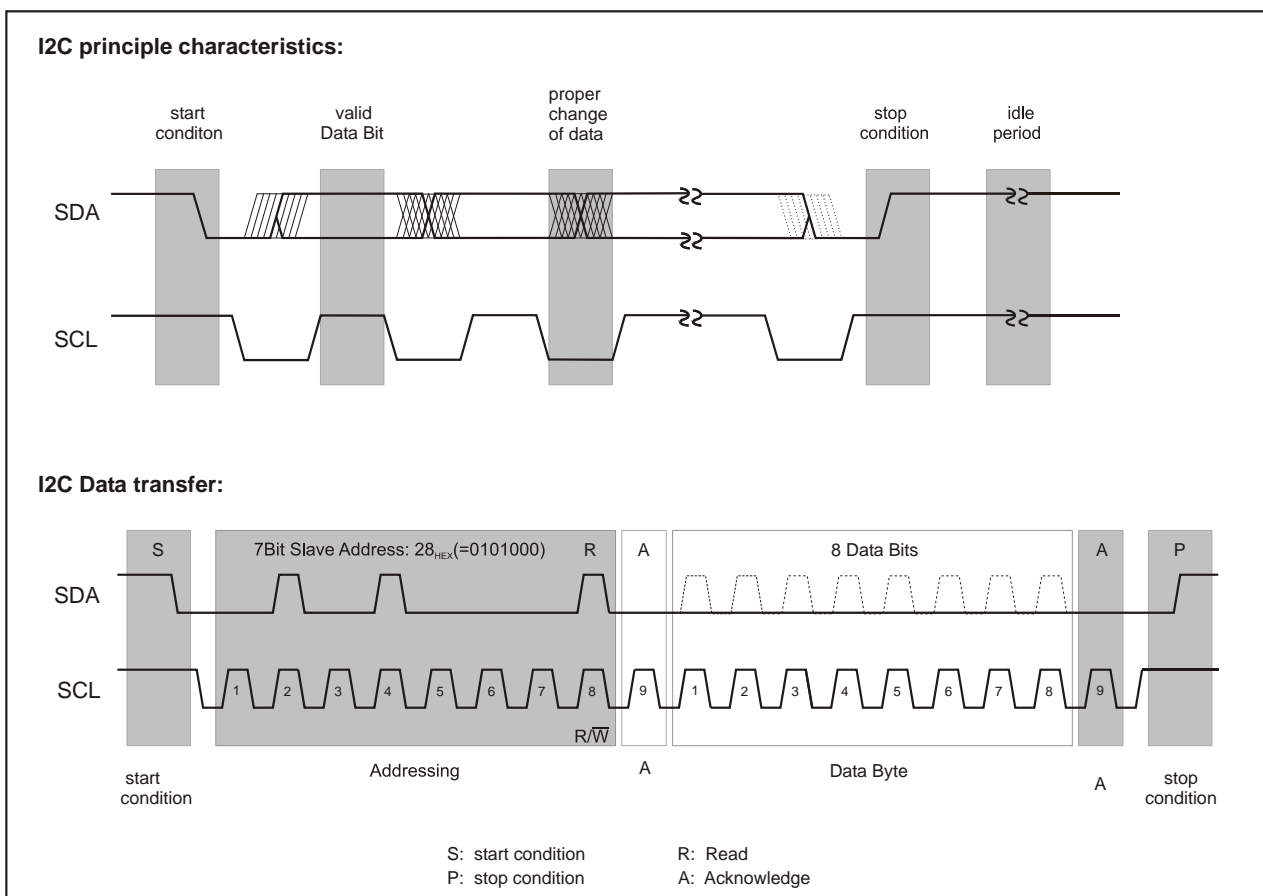

Figure 3: Standard I²C protocol

¹ There are three differences of AMS 6915 communication protocol compared to the original I²C communication protocol:

1. A stop condition directly after a start condition without clock pulses in between is not allowed. This creates a communication error for the next communication.
2. A second start condition (restart) during data transmission, when SCL is still high, is not allowed.
3. Between the start condition and the first rising SCL edge no a falling SDA edge is allowed.

AMS 6915

Amplified pressure sensor with digital output (I²C)

The I²C communication phases are as follows:

Idle period (bus is free)

When the bus is free, both I²C-bus lines (SDA and SCL) are pulled up to supply voltage level ("high level").

Start S (start condition)

Prior to any data transfer on the bus a start condition must be generated. The start condition is always sent by the I²C-master. The start condition is defined as a transition from "high level" to "low level" on the SDA line, while the SCL line is still on "high level". The digital data readout from AMS 6915 is always initiated by a start condition.

Stop P (stop condition)

The stop condition is always generated by the I²C-master after a data transfer has been completed. The stop condition is defined as a transition from "low level" to "high level" on the SDA line while the SCL line is still on "high level". The digital data readout from the AMS 6915 is always terminated by a stop condition.

Valid data

Data is transmitted in bytes (8 bits), starting with the most significant bit (MSB). One data bit is transmitted with each clock pulse. After a start condition the transmitted bits are only valid, if the level on the SDA line stays constant as long as the SCL line is on "high level". Changes to the SDA level must be made while the SCL line is on "low level".

Acknowledge A

After a byte has been transmitted the respective receiver (master or slave) has to send an acknowledge (additional acknowledge bit) confirming the correct receipt of the data. To this end the master generates an extra acknowledge-related clock pulse. The receiver sends the acknowledge bit by pulling the SDA line down to "low level" during the additional clock pulse.

Addressing / Slave address (I²C-address AMS 6915)

After the start condition the master sends an addressing byte (the first byte after the start condition) which determines which slave is selected. The addressing byte contains the individual 7 bit slave address of the selected slave (AMS 6915) and a data direction bit ($\overline{R/W}$). An "0" for the $\overline{R/W}$ bit indicates a transmission from master to slave (\overline{W} : write; the master wishes to transmit data to the selected slave), a "1" a data request (\overline{R} : read; the master requests data from the slave).

The pressure sensors in the AMS 6915 series have a standard, factory-programmed 7 bit slave address of 0x28_{Hex} (0101000_{bin}).

If more than one AMS 6915 have to be connected to the same I²C-bus, each pressure sensor requires an individual slave address. On request each AMS 6915 can be ordered with an individual 7 bit slave address programmed at the factory; 7 bit addressing allows 128 different addresses. Using the AMS 6915's USB starter kit the customer can program the individual slave address himself.

AMS 6915

Amplified pressure sensor with digital output (I²C)

DATA READOUT VIA THE I²C-INTERFACE

The digital output values for pressure (14 bit value) and temperature (11 bit value) are read out from the AMS 6915 output register via AMS 6915 I²C-interface. The data readout, which is illustrated in *Figure 4*, is done byte per byte.

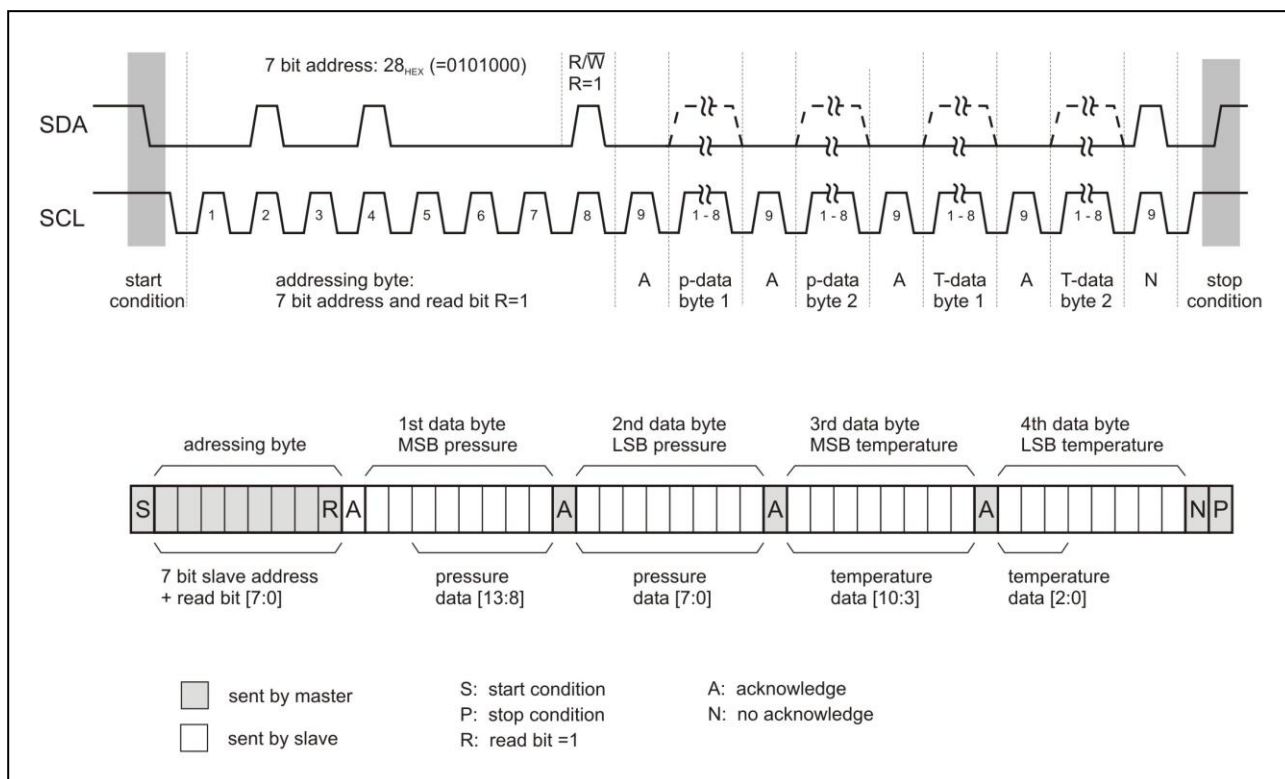

Figure 4: Data readout of the digital pressure and temperature values

Data transfer via the I²C-bus is always initialized by a data request from the I²C-master. For this purpose the I²C-master generates a start condition on the I²C-bus lines. Following the start condition the I²C-master then sends the addressing byte containing the 7 bit slave address of the AMS 6915 (programmed to 0x28_{Hex} = 0101000_{bin} at the factory) and the data direction bit R = 1 (indicating a data request) leading to the addressing byte 01010001_{bin}. The selected pressure sensor first answers with an acknowledge bit and starts the data transfer from the output register.

For pressure and temperature value readout a total of four data bytes are transmitted from the pressure sensor to the I²C-master. The two bytes for the current digital pressure value are sent first, followed by the two bytes for the current digital temperature value, always beginning with the most significant byte. On each transferred data byte the I²C-master sends an acknowledge bit confirming the correct receipt of data. After the fourth data byte the receiving master has to generate a no acknowledge bit, leading to the pressure sensor being set to inactive. The I²C-master shuts down the data transfer by sending a stop condition.

The 14 bit pressure value is given by the last 6 bits of the first data byte and the 8 bits of the second data byte always beginning with the most significant bit. The 11 bit temperature value is given by the 8 bits of the third data byte and the first 3 bits of the fourth data byte.

For pressure value readout only it is possible to stop the data transfer after two data bytes. In this case the I²C-master sends a no acknowledge bit after the second data byte and shuts down the data transfer by sending a stop condition.

AMS 6915

Amplified pressure sensor with digital output (I²C)

Calculating the current pressure and temperature value

To obtain the desired information on pressure and temperature in physical units the digital output values for pressure and temperature have to be converted.

The current pressure in bar (or PSI) can be calculated from the 14 bit digital pressure value using the following equation:

$$p = \frac{p_{Digout}(p) - p_{min,Digout}}{Sens_p} + p_{min} \quad \text{with} \quad Sens_p = \frac{p_{max,Digout} - p_{min,Digout}}{p_{max} - p_{min}} \quad (1)$$

with

p = current pressure in bar (or PSI, kPa)

$p_{Digout}(p)$ = current digital 14 bit pressure value in counts

$p_{min,Digout}$ = digital pressure value at minimum specified pressure (typ. 1638 counts)

$p_{max,Digout}$ = digital pressure value at maximum specified pressure (typ. 14745 counts)

$Sens_p$ = the pressure sensor's sensitivity in counts/bar (or counts/PSI, counts/kPa)

p_{min} = the pressure sensor's specified minimum pressure in bar (or PSI, kPa)

p_{max} = the pressure sensor's specified maximum pressure in bar (or PSI, kPa).

The current sensor temperature T in °C is calculated from the 11 bit digital temperature value $T_{Digout}(T)$ using the following equation:

$$T = \frac{T_{Digout}(T) \cdot 200}{2048} - 50 \quad \text{in } ^\circ\text{C} \quad (2)$$

Example

At the digital output of an AMS 6915-0005-D-B (bidirectional differential sensor, range: -5 .. 5 mbar) the following data bytes 1 .. 4 are read:

Byte 1: 00101100 Byte 2: 11001101 Byte 3: 01011100 Byte 4: 11100000

Taking the last 14 bits of byte 1 and byte 2 the current 14 bit digital pressure value is:

$$p_{Digout}(p) = (10110011001101)_{bin} \text{ counts} = (2CCD)_{Hex} \text{ counts} = 11469 \text{ counts}$$

and with the first 11 bits of byte 3 and byte 4 the digital temperature value is:

$$T_{Digout}(T) = (01011100111)_{bin} \text{ counts} = (2E7)_{Hex} \text{ counts} = 743 \text{ counts} .$$

With $p_{min} = -5 \text{ mbar}$, $p_{max} = 5 \text{ mbar}$ and $p_{min,Digout} = 1638 \text{ counts}$, $p_{max,Digout} = 14745 \text{ counts}$ specified for AMS 6915-0005-D-B the current pressure in mbar is calculated using equation (1) as:

$$p = \frac{(11469 - 1638) \text{ counts}}{(13107 / 10) \text{ counts} / \text{mbar}} + (-5 \text{ mbar}) = 2.5 \text{ mbar}$$

Using equation (2), the current sensor temperature in °C is calculated to:

$$T = \frac{(743 \cdot 200) \text{ counts} \cdot ^\circ\text{C}}{2048 \text{ counts}} - 50^\circ\text{C} = 22.6^\circ\text{C}$$

AMS 6915

Amplified pressure sensor with digital output (I²C)

DIMENSIONS AND PINOUT

AMS 6915-xxxx-D-H-x-DIL & AMS 6915-xxxx-D-B-H-x-DIL (horizontal pressure port configuration):

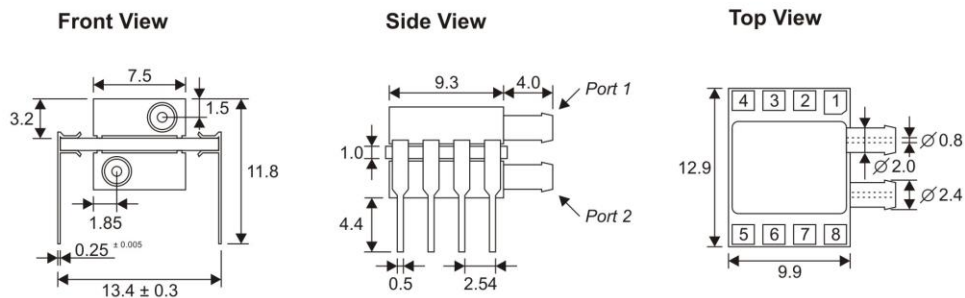

AMS 6915-xxxx-A-H-x-DIL & AMS 6915-1200-B-H-x-DIL (horizontal pressure port configuration):

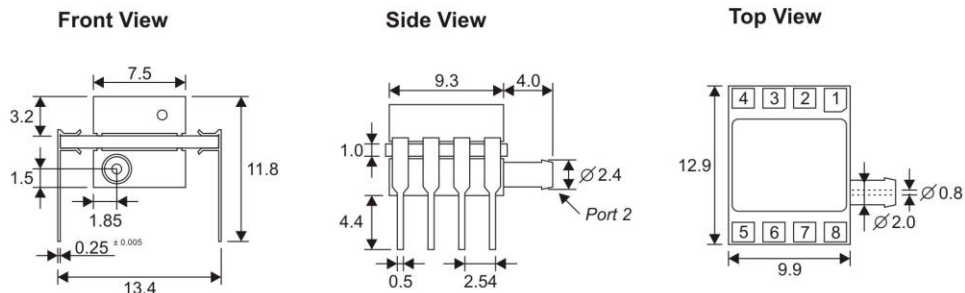

AMS 6915-xxxx-G-V-x-DIL (vertical pressure port configuration):

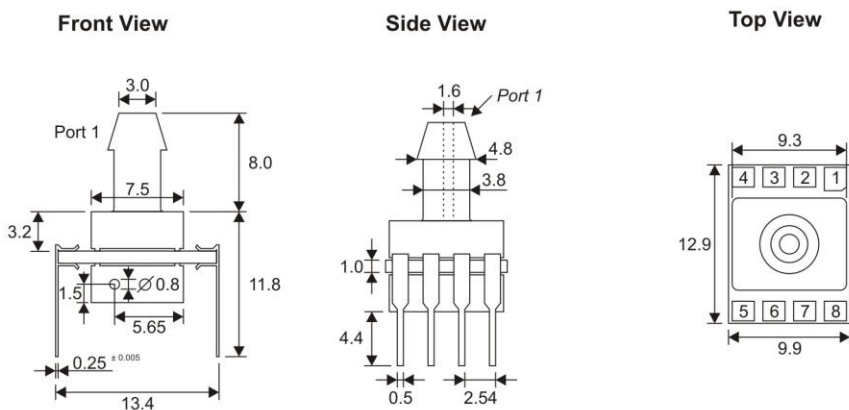

Pinout:

| Pin | Description |
|-------|-------------|
| 1 | GND |
| 2 | VS |
| 3 | SDA |
| 4 | SCL |
| 5 - 8 | N.C. |

All dimensions in mm, tolerances: ±0.1 mm unless otherwise noted

Figure 5: AMS 6915 dimensions and pinout

AMS 6915

Amplified pressure sensor with digital output (I²C)

ORDERING CODES

Horizontal pressure port configuration (DIL package)

With x = 3 for 3.3 V supply voltage models and x = 5 for 5 V supply voltage models.

| Ordering Code | mbar | kPa | PSI |
|---|----------------|----------------|--------------------|
| Differential pressure types (-D) | | | |
| AMS 6915-0005-D-H-x-DIL | 0 .. 5 | 0 .. 0.5 | 0 .. 0.0725 |
| AMS 6915-0010-D-H-x-DIL | 0 .. 10 | 0 .. 1 | 0 .. 0.145 |
| AMS 6915-0025-D-H-x-DIL | 0 .. 25 | 0 .. 2.5 | 0 .. 0.363 |
| AMS 6915-0050-D-H-x-DIL | 0 .. 50 | 0 .. 5 | 0 .. 0.725 |
| AMS 6915-0100-D-H-x-DIL | 0 .. 100 | 0 .. 10 | 0 .. 1.450 |
| AMS 6915-0200-D-H-x-DIL | 0 .. 200 | 0 .. 20 | 0 .. 2.901 |
| AMS 6915-0350-D-H-x-DIL | 0 .. 350 | 0 .. 35 | 0 .. 5.076 |
| AMS 6915-1000-D-H-x-DIL | 0 .. 1000 | 0 .. 100 | 0 .. 14.50 |
| Bidirectional differential pressure types (-D-B) | | | |
| AMS 6915-0002-D-B-H-x-DIL | -2.5 .. +2.5 | -0.25 .. +0.25 | -0.0363 .. +0.0363 |
| AMS 6915-0005-D-B-H-x-DIL | -5 .. +5 | -0.5 .. +0.5 | -0.0725 .. +0.0725 |
| AMS 6915-0010-D-B-H-x-DIL | -10 .. +10 | -1 .. +1 | -0.145 .. +0.145 |
| AMS 6915-0025-D-B-H-x-DIL | -25 .. +25 | -2.5 .. +2.5 | -0.363 .. +0.363 |
| AMS 6915-0050-D-B-H-x-DIL | -50 .. +50 | -5 .. +5 | -0.725 .. +0.725 |
| AMS 6915-0100-D-B-H-x-DIL | -100 .. +100 | -10 .. +10 | -1.450 .. +1.450 |
| AMS 6915-0200-D-B-H-x-DIL | -200 .. +200 | -20 .. +20 | -2.901 .. +2.901 |
| AMS 6915-0350-D-B-H-x-DIL | -350 .. +350 | -35 .. +35 | -5.076 .. +5.076 |
| AMS 6915-1000-D-B-H-x-DIL | -1000 .. +1000 | -100 .. +100 | -14.50 .. +14.50 |
| Absolute pressure types (-A) | | | |
| AMS 6915-1000-A-H-x-DIL | 0 .. 1000 | 0 .. 100 | 0 .. 14.5 |
| Barometric (absolute) pressure types (-B) | | | |
| AMS 6915-1200-B-H-x-DIL | 700 .. 1200 | 70 .. 120 | 10.88 .. 17.4 |

Vertical pressure port configuration (DIL package)

With x = 3 for 3.3 V supply voltage models and x = 5 for 5 V supply voltage models.

| Ordering Code | mbar | kPa | PSI |
|--|-----------|----------|------------|
| Relative (Gage) pressure types (-G) | | | |
| AMS 6915-0025-G-V-x-DIL | 0 .. 25 | 0 .. 2.5 | 0 .. 0.363 |
| AMS 6915-0050-G-V-x-DIL | 0 .. 50 | 0 .. 5 | 0 .. 0.725 |
| AMS 6915-0100-G-V-x-DIL | 0 .. 100 | 0 .. 10 | 0 .. 1.450 |
| AMS 6915-0200-G-V-x-DIL | 0 .. 200 | 0 .. 20 | 0 .. 2.901 |
| AMS 6915-0350-G-V-x-DIL | 0 .. 350 | 0 .. 35 | 0 .. 5.076 |
| AMS 6915-1000-G-V-x-DIL | 0 .. 1000 | 0 .. 100 | 0 .. 14.50 |

AMS 6915

Amplified pressure sensor with digital output (I²C)

ADDITIONAL EQUIPMENT

A USB starter kit with software is available for AMS 6915 sensors. This kit permits easy readout of the digital pressure and temperature values using a standard Windows PC. Furthermore, the starter kit can be used to set a permanent individual I²C slave address for a particular AMS 6915 sensor, allowing the readout of multiple sensors via the same I²C-bus.

| Ordering code | Description |
|--------------------------|---|
| USB starter kit AMS 6915 | AMS 6915 - starter kit (2 PCBs with software) |

NOTES

Analog Microelectronics GmbH reserves the right to amend any dimensions, technical data or other information contained herein without prior notification.