

# AMS 5812 AN01

## Interfacing AMS 5812 to an Arduino Uno

This application note describes, how to interface the OEM pressure sensor AMS 5812 [1] with an Arduino Uno development board [2]. To simplify the data readout via I2C Analog Microelectronics offers a suitable sensor shield connecting the AMS 5812 right on top of an Arduino Uno.

The Arduino Uno is a popular microcontroller development board featuring an Atmega microcontroller and several I/O-pins including an SPI as well as an I2C port and is often used to read data from sensors. To interface an AMS 5812 pressure sensor with an Arduino Uno Analog Microelectronics has designed a special sensor shield, the AMS 5812 – Arduino PCB [3] (available at [www.analog-micro.com](http://www.analog-micro.com)). This PCB can easily be mounted onto Arduino Uno's pin sockets and features all the connections needed to power AMS 5812 and read data from its I2C port without soldering. After inserting an AMS 5812 into the PCB's socket the system is ready to use (see *Figure 1*).

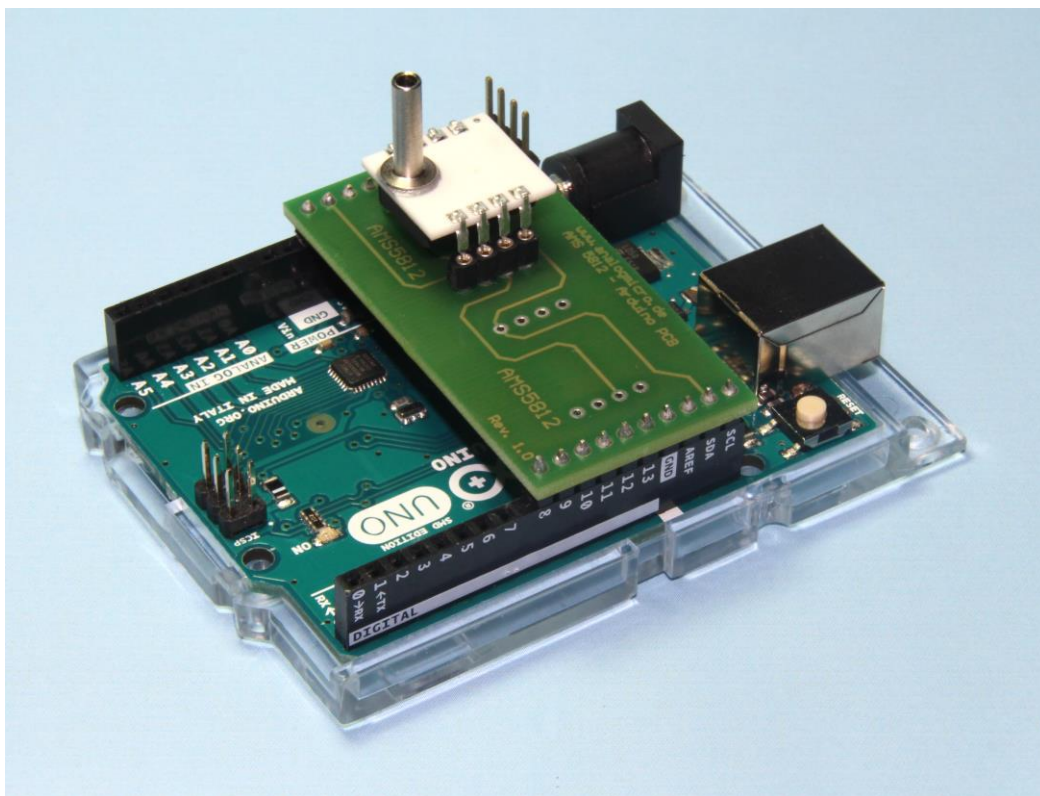

**Figure 1: Arduino Uno with AMS 5812 - Arduino PCB and an AMS 5812 pressure sensor**

Furthermore the AMS 5812 – Arduino PCB provides pins to connect another I2C device to the I2C bus via cable and a second port, which can be used to solder another AMS 5812 to the PCB.

Please note: If two AMS 5812 are connected to the I2C bus they have to have different I2C addresses (individual I2C addresses can be set using AMS 5812's starter kit [4] or sensors with pre-programmed individual addresses can be purchased from Analog Microelectronics. The standard I2C address  $0x78_{\text{HEX}}$  cannot be used for either of the sensors then).

*Figure 2* illustrates the principle electrical connections needed for I2C data readout of AMS 5812 using an Arduino and which are established by the AMS 5812 – Arduino PCB. Due to Arduino's internal pull-up resistors AMS 5812's SDA and SCL pins can be connected directly to Arduino's corresponding SDA and SCL

# AMS 5812 AN01

## Interfacing AMS 5812 to an Arduino Uno

ports on the PCB. Arduino's 5 V voltage source and GND are also connected to AMS 5812's corresponding pins directly.

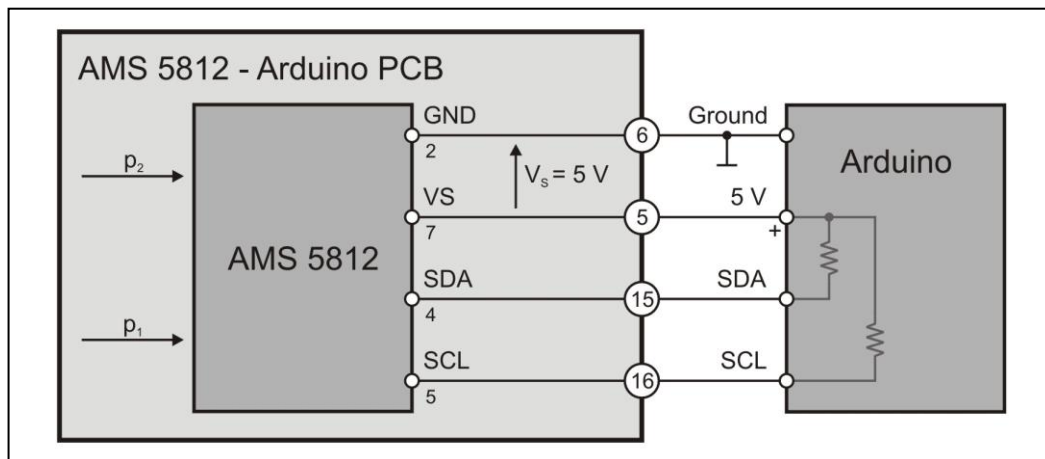

**Figure 2: Connecting AMS 5812 to Arduino**

To simplify programming Arduino Nano to read data from AMS 5812's I2C interface Analog Microelectronics has developed the AMS Arduino library [4] for Arduino's integrated development environment (IDE) [5]. It is described in the document "Arduino library for AMS 5812, AMS 5915, AMS 6915" [6] and can be downloaded for free from [www.analog-micro.com](http://www.analog-micro.com). With this library the digital pressure and temperature values can easily be read via I2C as soon as the electrical connection between AMS 5812 and Arduino Nano is established and the Arduino Nano is powered. Following the description in the library reference [6] it is only necessary to adjust the pressure range in the initialization sequence to the sensor's pressure range and the sensor's I2C address.

### References:

- 1.) AMS 5812's data sheet  
(see <https://www.analog-micro.com/products/pressure-sensors/board-mount-pressure-sensors/ams5812/ams5812-datasheet.pdf>)
- 2.) Arduino Uno (<https://www.arduino.cc/en/Main/ArduinoBoardUno>)
- 3.) AMS 5812 – Arduino PCB (available at <https://www.analog-micro.com>)
- 4.) AMS 5812's starter kit  
(see <https://www.analog-micro.com/products/pressure-sensors/board-mount-pressure-sensors/ams5812/ams5812-UsersGuide-starterkit.pdf>)
- 5.) Arduino's IDE (<https://www.arduino.cc/en/Main/Software>)
- 6.) AMS Arduino library "AMS.zip" (see <https://www.analog-micro.com/products/pressure-sensors/board-mount-pressure-sensors/ams5812/AMS.zip>)
- 7.) AMS Arduino library reference  
(available at [https://www.analog-micro.com/products/pressure-sensors/board-mount-pressure-sensors/ams5812/AMS\\_arduino\\_lib.pdf](https://www.analog-micro.com/products/pressure-sensors/board-mount-pressure-sensors/ams5812/AMS_arduino_lib.pdf))